

## GENERAL CHARACTERISTICS



The pressure switches PSV4 series use, as sensitive element, a diaphragm or a piston depending on the measuring range.

An electrical contact, NO, NC, or SPDT is turned on when the set value is reached.

The calibration value, when required, is shown in the description of master data. The adjusting screw is mounted on the head of the instruments, you can set the calibration value, within the entire measuring range. Appropriate mechanical stops protect the electrical contact from excess of pressure. The electrical connections, fast-on or screw type, may be protected by protection cap IP54.

These pressure switches are used in hydraulic and pneumatic equipment, in the industrial plants, pumps, machine tools etc..



K4 F



K4 O



F4 P3

- Pressure control from 0.2 to 400 bar.
- Easy to use and adjust.
- Easy to install.

## SETTING RANGES

Tab.1

Diaphragm	Piston	Tolerance value	Hysteresis fixed	P max bar			T max (°)	Code	
				Brass	Steel	Inox		°C	
bar	bar	bar	bar						
0,2 - 2,5	-	± 0,15	± 0,25	25	25	25	-20/+80	025	R
1 - 12	-	± 0,6	± 1,2	25	25	25	-20/+80	012	S
1 - 12	-	± 0,6	± 1,2	150	150	150	-20/+80	012	SM
5 - 50	-	± 2,5	± 5,0	150	150	150	-20/+80	050	TM
-	1 - 12	± 0,6	± 2,4	300	300	300	-20/+80	012	P
-	5 - 50	± 2,5	± 10	300	300	300	-20/+80	050	T
-	10 - 100	± 5,0	± 20	300	300	300	-20/+80	100	V
-	20 - 200	± 10	± 40	300	300	300	-20/+80	200	Z
-	50 - 400	± 20	± 100	600	600	600	-20/+80	400	Y

(\*) Reference to NBR diaphragm, stainless steel piston / NBR seals

Factory set - Decreasing	00D	..	Letter of range code
Factory set - Increasing	00U	..	

► The set point value is shown in description master data ◀

## TECHNICAL DATA

Tab.2

	Description	S Standard		Code	
		R	On request		
Body	Tropicalized steel	S	-	(-)	
	Brass	-	R	L	
	Stainless steel AISI-316	-	R	X	
Diaphragm and seals		°C			
	NBR	-20/+80	S	-	(-)
	EPDM	-20/+90	-	R	E
	VITON	-20/+150	-	R	V
Piston	PTFE	-30/+200	-	R	T
	St. steel AISI-316	-30/+140	S	-	(-)

	Description	S Standard		Code	
		R	On request		
Process connection	1/8" M - UNI 228/1	-	R	0	
	1/8" M - UNI 7/1	-	R	2	
	1/8" M - NPT	-	R	4	
	1/4" M - UNI 7/1	-	R	6	
	1/4" M - UNI 228/1	S	-	1	
	1/4" M - NPT	-	R	5	
	M10x1 Taper	-	R	3	
Contact	250 VAC 0,5A	NA	S	-	K4A
	48 VDC 0,2A	NC	S	-	K4C
	250VAC 0,5A	SPDT	-	R	F4
	48 VDC 0,2A				
Electrical output	Faston 6,3 x 0,8 mm	NA-NC	S	-	F
		SPDT	-	R	P3
	Screw connection	NA-NC	S	-	O
Protection	-	S	-	IP00	
	IP54	-	R	P1	
-	Mechanical life	10 <sup>6</sup> cicli	S	-	-
-	Switching frequency	90 cycle/min	S	-	-

## ADJUSTMENT

To adjust the set point, turn the screw located into the head of the pressure switch.

- Clockwise = Increase (+)
- Counterclockwise = decrease (-)

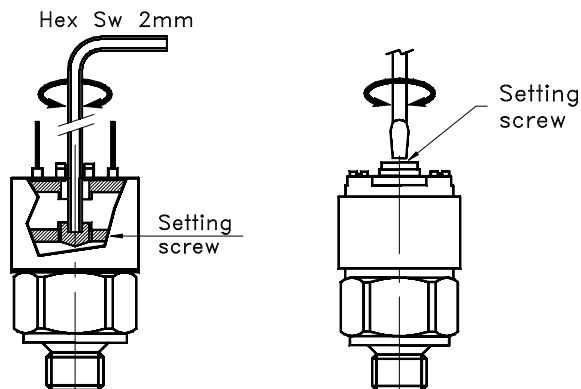

## WIRING

Tab.3



NO

K4A

NC

K4C

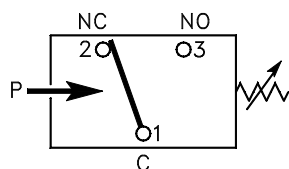

SPDT

F4

## PROTECTION - on request

Tab.4

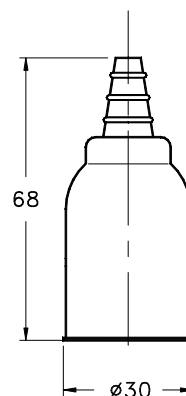

IP54

P1

## DIMENSIONS mm.

Tab.5

Terminals							C	Code
Faston			Screw					
K4A	K4C	F4	K4A	K4C				
A	B	A	B	A	B			
47	9	47	9	42	9	1/8" M - UNI 228/1	0	
47	9	47	9	42	9	1/8" M - UNI 7/1	2	
47	9,5	47	9,5	42	9,5	1/8" M - NPT	4	
47	14,4	47	14,4	42	14,4	1/4" M - UNI 7/1	6	
47	10,5	47	10,5	42	10,5	1/4" M - UNI 228/1	1	
47	14,4	47	14,4	42	14,4	1/4" M - NPT	5	
47	9	47	9	42	9	M10x1 - Taper	3	

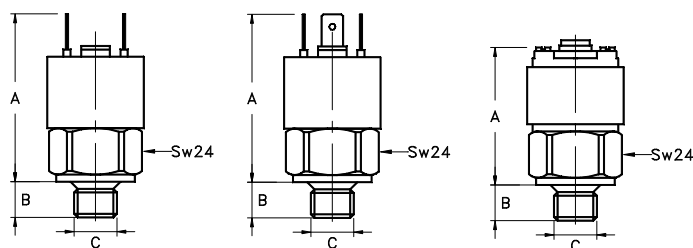

Faston - IP00

Faston - IP00

Screw terminal IP00

K4A - K4C

F

F4

P3

K4A - K4C

O

## NOMENCLATURE

PSV K4 012-S F (-) (-) 0 IP00

PSV	K4	012-S	F	(-)	(-)	0	IP00		
•								-	Type
	•							Tab.2-3	Contact type and wiring
		•						Tab.1	Adjustable range or Setting – sensing element
			•					Tab.2-5	Electrical output – Terminals type
				•				Tab.2	Body material
					•			Tab.2	Diaphragm / piston material
						•		Tab.2-5	Process connection
							•	Tab.2	Degree of protection
P1	Protection cap – IP54							Tab.4	Accessory on request